

Ekorooftile Roof Penetration Detail

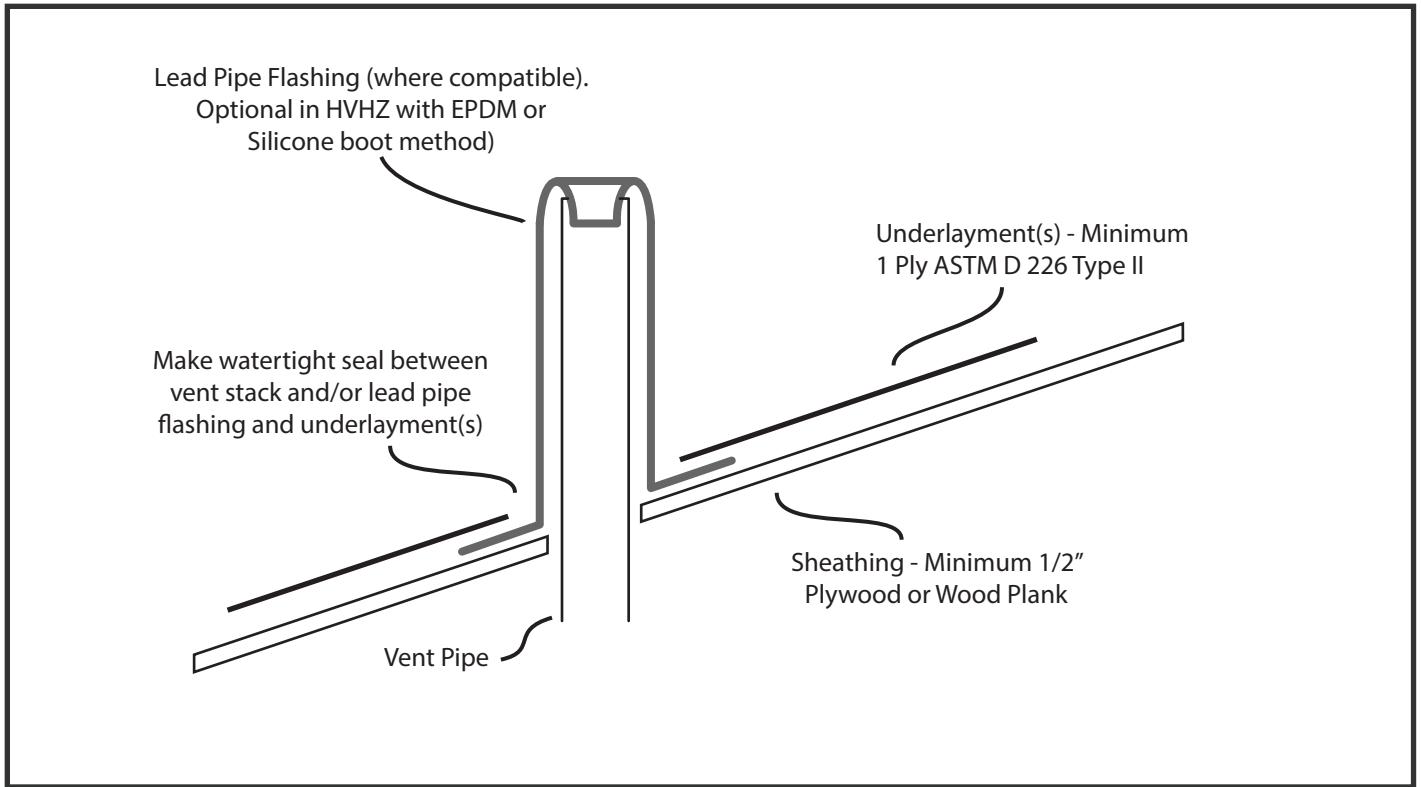

EPDM or Silicone Pipe Boot Method

Note: This Method for use within HVHZ

Also note: This method is to be used with gas vents, goosenecks, roof jacks, APV vents, or other types of vent stack penetrations through roof deck and Ekorooftile covering, also including Solar Power Panel or other equipment rack or attachment penetrations. For ease of installation, all non-round penetrations should be substituted with equivalent and approved round pipes when possible, provided flow or function are not affected.

Lead Flashing Optional when using Silicone or EPDM Boot

Hose clamp, if required by boot manufacturer

EPDM or Silicone Vent Pipe Flashing

Sealant

Ekorooftile

Do not penetrate underlayment(s) or sheathing. If penetrating deck cannot be avoided due to vent location, such as in a low point of tile, use 2" main Ekorooftile fastener, color-matched for aesthetics.

Fastener is 1" #10-13 Corrosion Resistant & Approved Screw with 1/4" Hex or Concealor/Pancake Head, color-matched to tile for aesthetics.



Apply a full bead of sealant at joint of boot flashing with lead pipe flashing & joint with Ekorooftile. Sealant type is Ekorooftile Vent Pipe Flashing Sealant, NPC Sealants Solar Seal 900® or equivalent.

Boot base fasteners shall be applied 4" O.C.

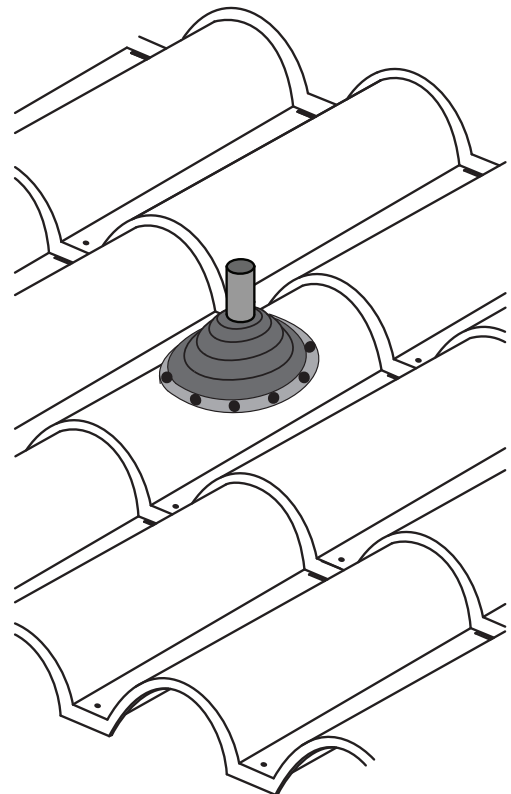

drawings not to scale

Ekorooftile Gooseneck Penetration Detail

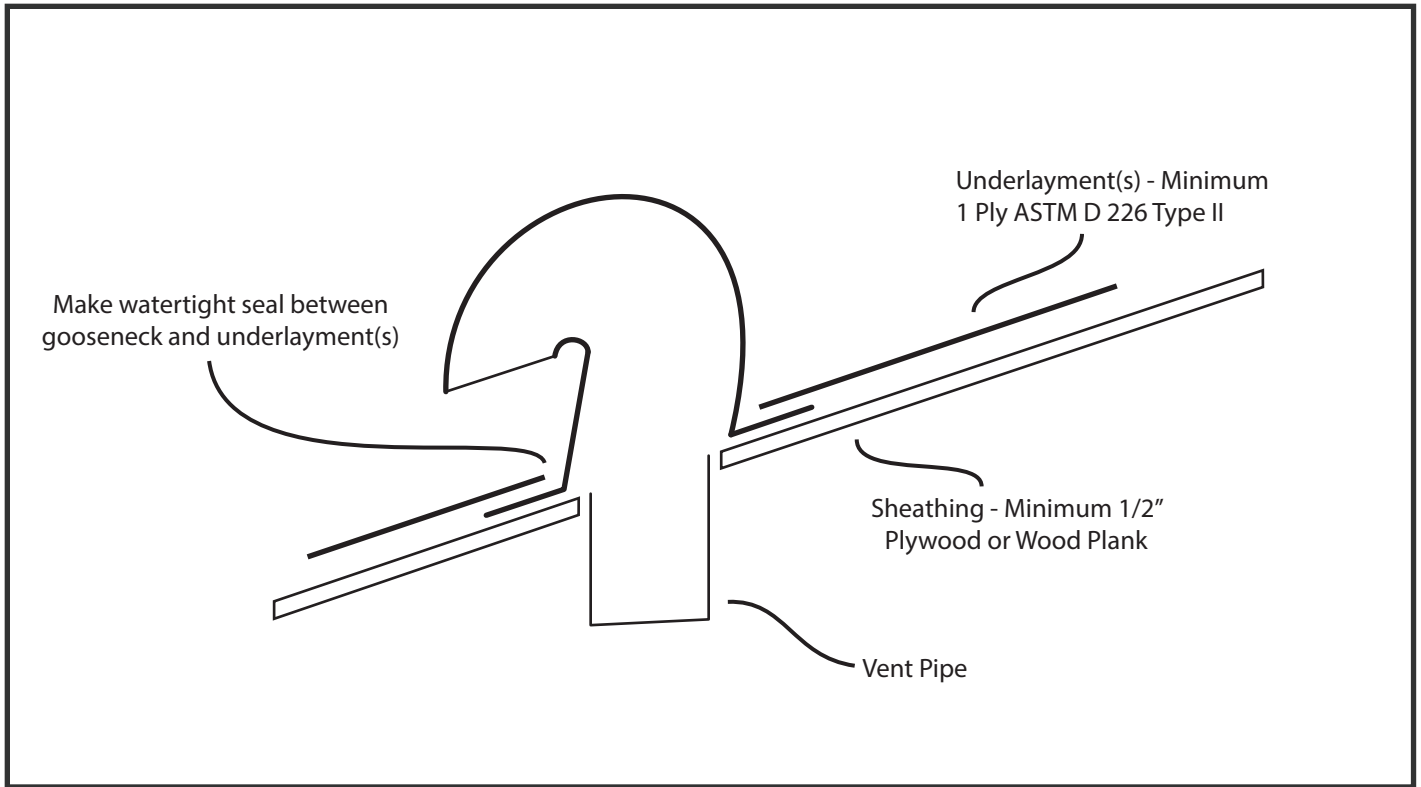

Flexible Flashing Method

Note: This Method for use within HVHZ
 Also note: This method is to be used with rectangular penetrations such as skylights and vents.

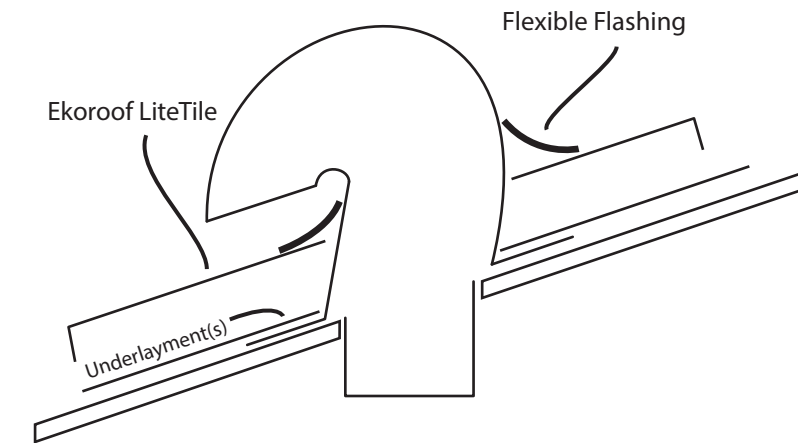

Recommended flexible flashing brand is DEKS® brand KwikFlash® with aluminum mesh

Do not penetrate underlayment(s) or sheathing. If penetrating deck cannot be avoided due to vent location, such as in a low point of tile, use 2" main Ekorooftile fastener, color-matched for aesthetics.

Fastener is 1" #10-13 Corrosion Resistant & Approved Screw with 1/4" Hex or Concealor/Pancake Head, color-matched to tile for aesthetics.



Ensure Ekorooftile is dry and clean of oils, dust and dirt and apply the self-adhered flashing beginning down-slope and overlapping as needed, up-slope in shingle fashion. Ensure flashing extends 4" away from the base of the penetration and at least 2" vertically on the item to be flashed. Fasten perimeter with a 1" wide aluminum termination bar fastened every 6" O.C.

Mortar Method

Note: Not approved for HVHZ

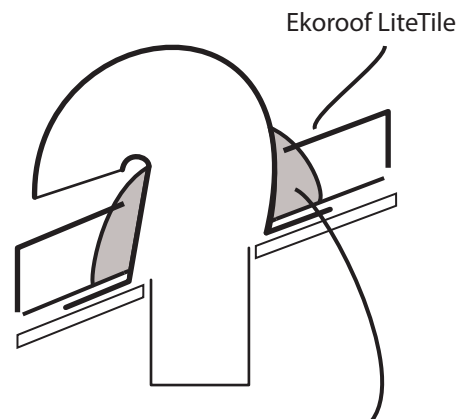

Fully seal gooseneck to Ekorooftile using Roofing Mortar color-matched to tile for aesthetics

drawings not to scale

Ekorooftile Gooseneck Penetration Detail

Flexible Flashing Method

Note: This Method for use within HVHZ
Also note: This method is to be used with rectangular penetrations such as skylights and vents.

Recommended flexible flashing is DEKS® brand KwikFlash®, DekStrip®, or FastFlash®, self-adhered rubber flashing with aluminum mesh

Instructions, details, and specifications for DEKS® Products can be found at <http://www.deks.com.au/>

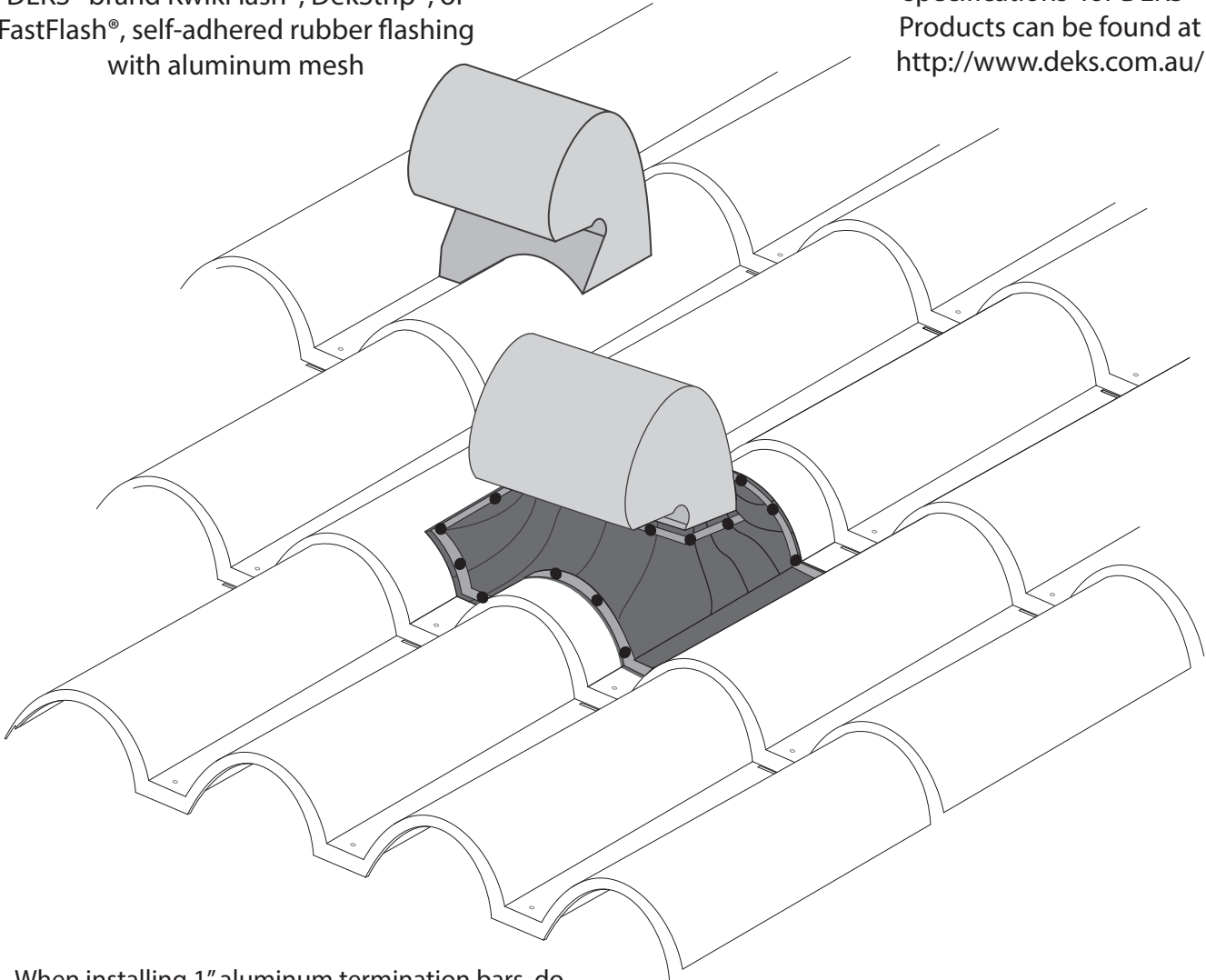

When installing 1" aluminum termination bars, do not penetrate underlayment(s) or sheathing. If penetrating deck cannot be avoided due to vent location, such as in a low point of tile, use 2" main Ekorooft fastener, color- matched for aesthetics.

Fastener is 1" #10-13 Corrosion Resistant & Approved Screw with 1/4" Hex or Concealor/Pancake Head, color-matched to tile for aesthetics.

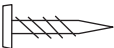

Ensure Ekorooftile is dry and clean of oils, dust and dirt and apply the self-adhered flashing beginning down-slope and overlapping as needed, up-slope in shingle fashion. Ensure flashing extends 4" away from the base of the penetration and at least 2" vertically on the item to be flashed. Fasten perimeter with a 1" wide aluminum termination bar fastened every 6" O.C.

drawings not to scale